



4-Beam-Turbidity Meter

Application

- turbidity measurement from 0 up to 5000NTU resp. 0 up to 1250EBC
- filter monitoring
- phase separation of low turbid media

Application Examples

- process control of brewing processes
- fresh water control in the beverage industry
- water- / waste water control e.g. in dairys
- quality control

Hygienic Design / Process Connection

- CIP-/ SIP-cleaning up to 130°C
- fitting completely made of stainless steel, optical block made of PEEK, glass panes made of sapphire glass (FDA-conform)
- further process connections: dairy flange DIN11851, hygienic thread connection DIN11864-1 form A, TriClamp, DIN flange

Features

- pollution of the glass panes will be compensated
- compact device, no separate evaluation unit necessary
- units NTU and EBC switchable (11 ranges per unit)
- smallest measurement range 0...5NTU resp. 0...1EBC
- highest measurement range 0...5000NTU resp. 0...1250EBC
- 4 externally switchable measurement ranges
- smallest pipe diameter DN40
- colour independent measurement principle (wave length 860nm)
- switching and analog output

Options / Accessories

- electrical connection with M12 plug-in
- cable ex factory for M12 plug-in
- other process connections on request



ITM-4-GG80

Specification

Process connection	dairy flange DIN 11851	DN 40; 50; 65; 80; 100
	hyg. conn. DIN 11864	DN 40; 50; 65; 80; 100
	DIN-flange	DN 40; 50; 65; 80; 100
	TriClamp	DN 40; 50; 65; 80; 100
Materials	connection head	SS 1.4305 89mm dia.
	fitting	SS 1.4404
	optical block	PEEK
	glass panes	sapphire glass
Temperature ranges	ambient	-10...+60°C
	process	0...100°C
	CIP-/ SIP-cleaning	up to 130°C 30 min max
Pressure		6bar max
Protection type		IP69K
Measurement principle	acc. to EN 7027	4-beam-altern. light
Wave length	acc. to EN 7027	860nm ± 60nm
LCD-Indicator	with illumination	2x8-digit
Accuracy		see page 4

Electr. connection	cable entry	2xPG (M16x1,5)
	cable connection	2xM12 plug-in (SS 316)
	supply voltage	18...36V DC 160mA max.
Input	range switching	E1 and E2 (24V DC) DC decoupled
	Output	analog
short circuit proof	switching	DC decoupled 24V DC 80mA max. respectively to GND of power supply
	Measurement ranges	NTU
EBC		0-1; 2; 5; 10; 20; 50; 100; 200; 500; 1000; 1250
Damping time	seconds	0; 1; 2; 4; 8; 16; 32; 64; 128

Order Code

Device	Process connection	Pipe diameter DN	Electr. connection
ITM-4	GG (dairy flange DIN 11851)	40 / 50 / 65 / 80 / 100	X (M16x1,5) M12 (M12-plug-in)
	HH (hyg. thread conn. DIN 11864-1 form A)		
	DF (DIN flange)		
	TC (TriClamp)		
Order example:	ITM-4-GG-65 / M12		



Mechanical connection/Mounting instructions

- Ensure that the mounting position of the turbidity meter guarants that the fitting is always full with media. Air or airbubbles are measured like turbidity.

Correct installation:

- In or in front of ascending pipes!

Wrong installation:

- In or in front of descending pipes!
- Into the highest point of a pipe. Air or airbubbles will concentrate there.

Take attention to the margin drawings!

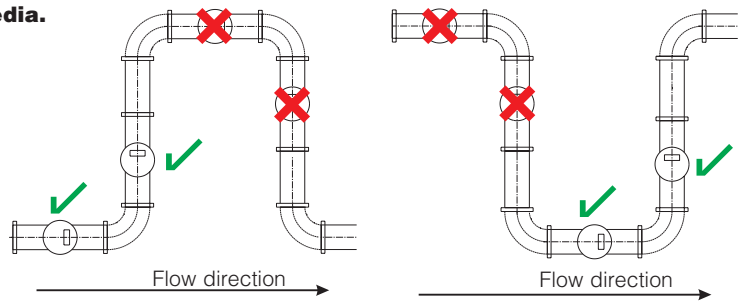

- Do not open the screws at the optical block of PEEK!

Turning the display

1. Loosen the grub screws (1) on top and bottom resp. on the left and right.
2. Turn the head to the desired position. Turnig is possible only in steps of 90°!
3. Tighten the two scrub screws.

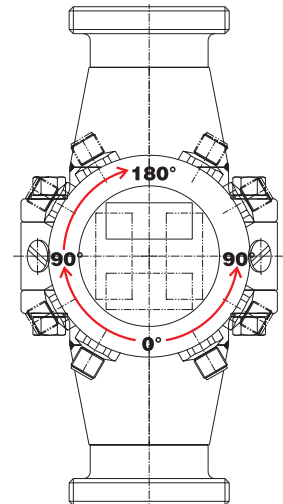
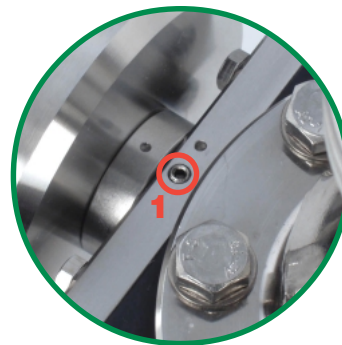

External measurement range selection

- The turbidity meter is delivered with measurement range 1 (0...1000NTU / 0-1000EBC = 4-20mA)
- Range 2 (E1=24VDC), range 3 (E2=24VDC) and range 4 (E1=24VDC and E2=24VDC) can be chosen by means of the rated signal +24VDC (18...36VDC) at the inputs on pin 7, 8 and 9. Please take note of the connection plan and the table below.
- If these inputs are not connected, measurement range 1 always will be active!

Measurement range selection

E1	E2	Range
0	0	1
1	0	2
0	1	3
1	1	4

The digital inputs E1 and E2 are DC decoupled to the power supply. Reference ground: pin 9

0 ≙ 0V DC; 1 ≙ 24V DC

Connecting Diagram ITM-4 / M12 with M12 plug-in

M12 plug-in left
power supply/ output 4-20mA

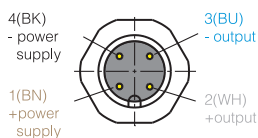

M12 plug-in right
switching output / control voltage

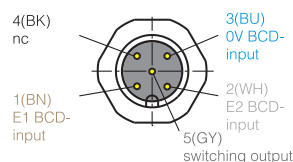

Note: Switching output

- If the output current is higher than the specified current (80mA) an electronic fuse switches off the output.
- To reset the switch output disconnect the output (or deactivate and activate the turbidity meter).

Electrical Connection

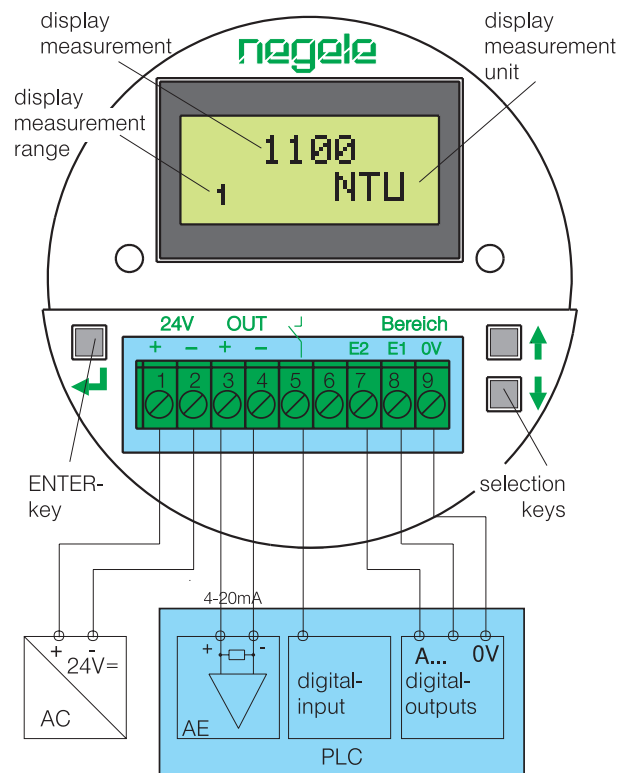

Adjustment ITM-4

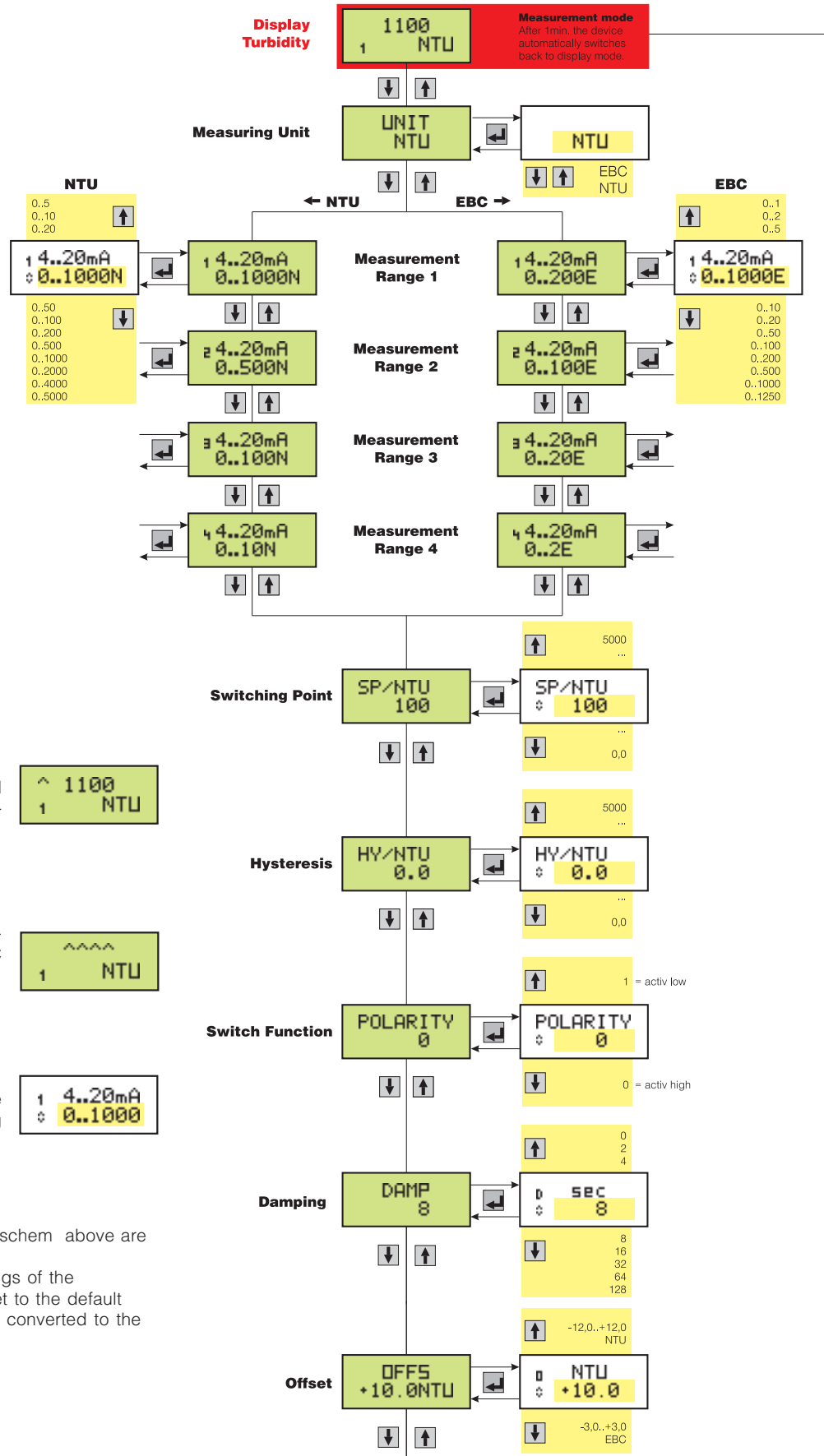

Legend

^-Symbol

"current output overload":
will be displayed if the measured
value is higher than the measure-
ment range.

$I_{out} > 20mA$ (21,6mA max.)

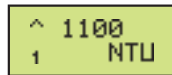

^^^^ -Symbol

the current measured value is hig-
her than 5000NTU resp. 1250EBC
 $I_{out} > 20mA$ (21,6mA max.)

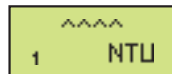

1 (left side above)

current editable measurement
range **1-Symbol** the value in the
margin is now editable by using
the arrow-buttons

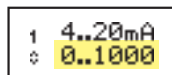

Default Settings

- The values in the adjustment schem above are the default settings.
- If the unit is changed, all settings of the measurement ranges are preset to the default settings. The adjusted offset is converted to the other unit.

Dimensioned Drawings ITM-4

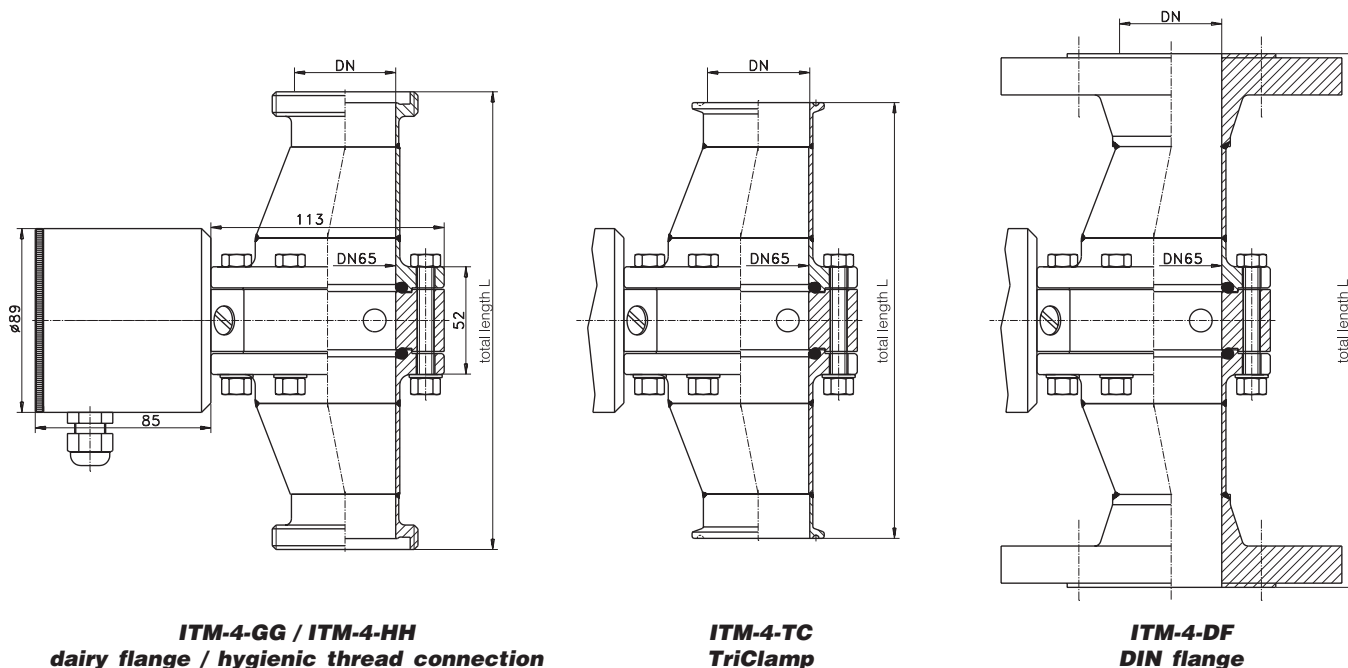

ITM-4-GG / ITM-4-HH
dairy flange / hygienic thread connection

ITM-4-TC
TriClamp

ITM-4-DF
DIN flange

Table total length of the fitting (tol.: ±2mm)

Process-connection / nominal width	dairy flange (-GG) acc. to DIN11851	hygienic screw connection (-HH) acc. to DIN11864-1 form A	TriClamp (-TC) acc. to DIN32676	DIN flange (-DF) acc. to DIN2632/33
DN40	298,0mm	284,0mm	275,0mm	316,0mm
DN50	236,0mm	226,0mm	209,0mm	256,0mm
DN65	250,0mm	236,0mm	256,0mm	290,0mm
DN80	250,0mm	236,0mm	216,4mm	260,4mm
DN100	378,0mm	362,0mm	320,8mm	368,8mm

Accuracy:

Accuracy	at the calibration points (20; 200; 2000NTU)			+ -2%
Offset dirt				<+ -0,3NTU (+ -0,075EBC)
Slope accuracy	Range	0...1000NTU	(0...250EBC)	<3%
	Range	1001...2000NTU	(250...500EBC)	<4%
	Range	2001...5000NTU	(500...1250EBC)	<6%
Reproducibility	Range	0...1000NTU	(0...250EBC)	<2%
	Range	1001...2000NTU	(250...500EBC)	<3%
	Range	2001...5000NTU	(500...1250EBC)	<4%
Resolution	Range	0...100NTU	(0...25EBC)	0,1NTU (0,025EBC)
	Range	100...1000NTU	(25...250EBC)	1NTU (0,25EBC)
	Range	1001...5000NTU	(250...1250EBC)	10NTU (2,5EBC)

To ensure the accuracy data above, we suggest you to send back the turbidity meter every two years for checking it.