

Buffer Amplifiers

v_{tv}, z_{tv}

General Function

Buffer amplifiers **v_{tv}** and **z_{tv}** serve to DC decouple scaled signals (0-10V, 0/4-20 mA). Input and output signals are freely selectable by means of slider switches, thus enabling the amplifier to be set in the field.

Buffer amplifier **v_{tv}** and **z_{tv}** converts the input signal into an optical signal which is converted back into a voltage or current signal in the output stage. On both versions zero and slope can be calibrated by means of trimmers to undertake adaptation. Buffer amplifiers **v_{tv}** and **z_{tv}** are incorporated in a snap-on casing for a standard mounting rail.

Features

- isolating voltage 1kV
- variable zero and gain
- slim-line version **z_{tv}** (22.5mm)
- plug-in terminal block connections
- scaled signal in/output selectable
- customized ranges on request
- CE-registration

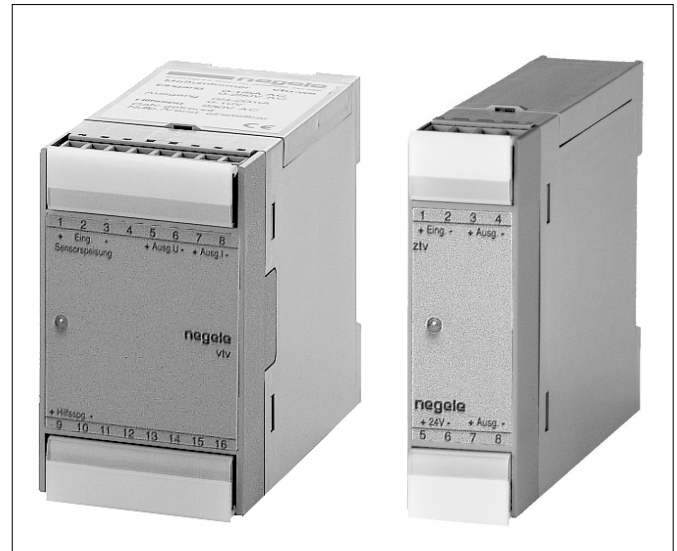

Buffer Amplifier **v_{tv}** Buffer Amplifier **z_{tv}**

Specification

Style	DIN standard case (shoulder-to-shoulder mounting) of ABS 45x75x105mm	
v_{tv}	22.5x75x105mm	
z_{tv}	for mounting rail as per EN 50022	
Enclosure code	IP 20, guarded terminals	
Ambient:	operating temperature +10...+40°C shelf temperature -20...+70°C humidity 0-95% no condensate	
Input	selectable current 0/4...20mA voltage 0...10V	R = 50Ω R = 50 kΩ
Output	voltage 0...10V current 0/4...20mA	load > 1 kΩ burden ≤ 500Ω
v_{tv}	voltage 0...10V current 0/4...20mA	load > 1 kΩ burden ≤ 500Ω
z_{tv}	voltage 0...10V current 0/4...20mA	load > 1 kΩ burden ≤ 500Ω
Sensor supply	approx. 20 V DC/max 25 mA only v_{tv}	
Accuracy	±0.2% of HI linearity temp. drift	0.1% typ. 0.05% per 10K
Isolating voltage	input-output in/output-supply volt.	1kV 4kV if AC, 1kV if DC
Transformer freq.	<10Hz	
Supply voltage	230, 110, 42, 24 V AC, 47...63 Hz, 5VA	
v_{tv}	24 V DC max. 150 mA	
z_{tv}	24V DC 80 mA	
	max. voltage tolerance -10%/+15%	

Order Code

You must specify the following when ordering:

Designation	Type	Supply Voltage
Buffer amplifier	v _{tv}	230 V AC
Buffer amplifier	v _{tv}	24 V AC
Buffer amplifier	z _{tv}	24 V DC

Pin Assignments

v_{tv}

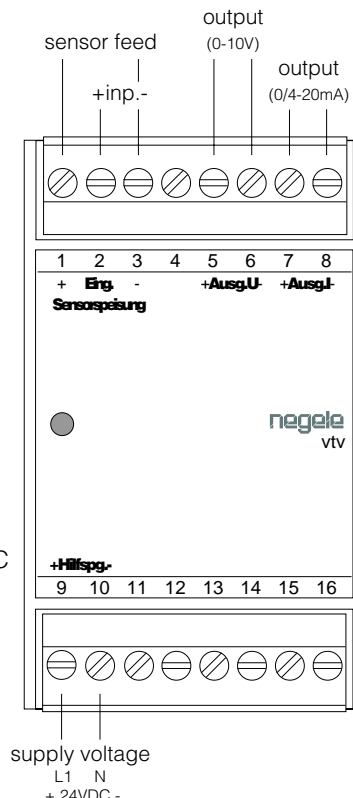

z_{tv}

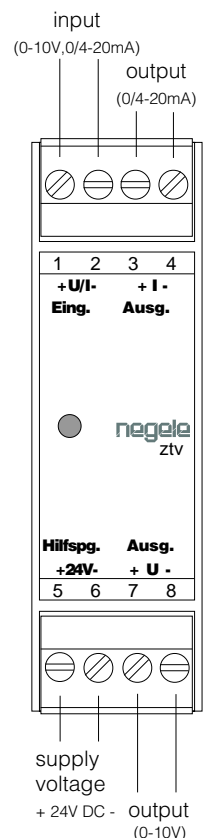

Trimmers and Selector Switches

- P1 zero (Np) adjustment range $\pm 0,2\text{mA}/0,1\text{V}$ (**vtv**), $\pm 2\text{mA}/1\text{V}$ (**ztv**)
- P2 gain (V), adjustment range $\pm 30\%$ (**vtv**), $\pm 15\%$ (**ztv**)
- S1 selector input (I/U) current (I) or voltage (U)
- S2 selector input (Ein0/4) 0...20mA or 4...20mA
- S3 selector output (Aus0/4) 0...20mA or 4...20mA

Range Settings

Amplifier input and output ranges can be set according to the following Table:

Input	Output	Selector Position		
		S1(EinI/U)	S2(Ein0/4)	S3(A0/4)
0-20mA	0-20mA	I	0	0
	4-20mA	I	0	4
	0-10V	I	0	0
4-20mA	0-20mA	I	4	0
	4-20mA	I	4	4
	0-10V	I	4	0
0-10V	0-20mA	U	0	0
	4-20mA	U	0	4
	0-10V	U	0	0

Calibration Procedure

Recalibration of the amplifier is implemented as follows:

1. Set amplifier to desired in/output combination as indicated in table.
2. Connect setpoint transmitter to input (pins 2 and 3 on **vtv**, pins 1 and 2 on **ztv**)
3. Loop ammeter (range 20 mA DC) in current output line or connect voltmeter (range 10 V DC) in parallel to voltage output of **vtv** or **ztv** (see block diagram 2 „Calibration“)
4. Apply supply voltage (pins 7 and 8 on **vtv**, pins 5 and 6 on **ztv**)
5. Apply zero signal (0/4mA or 0V) to input.
6. Using trimmer P1 (Np) set output to 0mA (4mA on output 4-20) or 0V.
7. Apply max. input signal (20 mA or 10V)
8. Using trimmer P2 (V) set output to 20mA or 10V.
9. Check intermediate values.

**Block Diagram 1:
vtv with two-wire sensor connected**

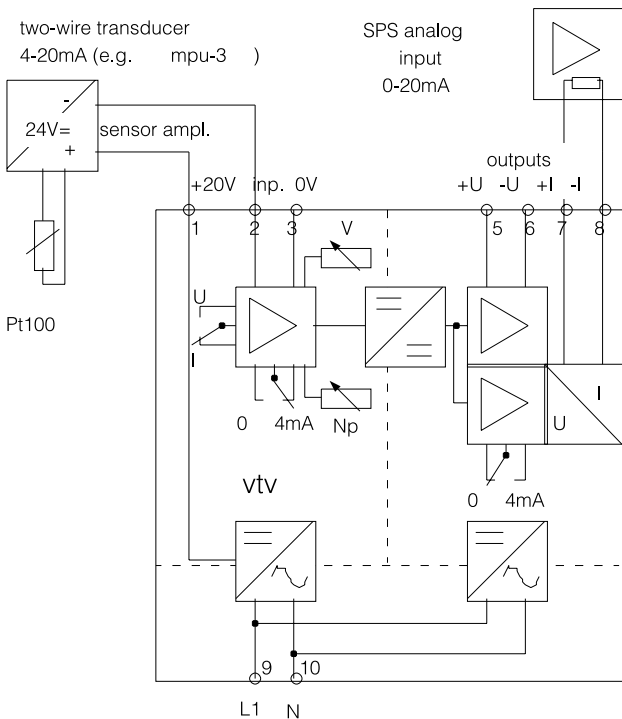

**View vtv
(cover open)**

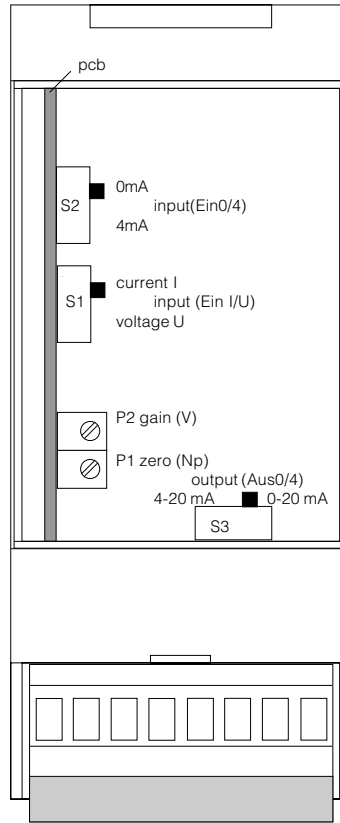

**View ztv
(cover open)**

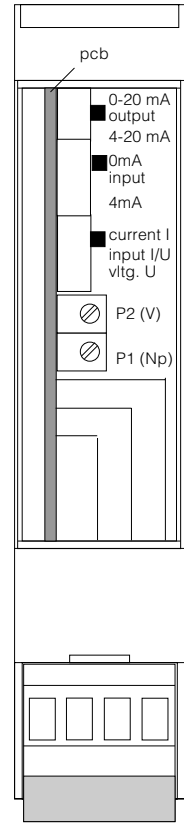

**Block Diagram 2:
ztv with calibration arrangement**

