

## Alarm Relays

## vgw-e,-ec, vgw-d,-dc

### General Function

Alarm relays type **vgw-...** -serve to output alarms on standard signals (0-10V, 0/4-20mA). The relay monitors a single alarm (**vgw-e/-ec**) or two alarms (**vgw-d/-dc**), a floating changeover contact serving in each case as the output.

As soon as the set value is attained, the corresponding output relay is switched. The input signal (0-10V, 0/4-20mA) and the required switching function (MAX or MIN alarm) is selectable by means of slider switches.

The alarm values will be set by means of a potentiometer (**vgw-e**) or trimmer (**vgw-d**) or coding switches (**vgw-ec, vgw-dc**).

### Features

- zero, gain and hysteresis all adjustable
- plug-in terminal connections
- input switchable to all standard signals
- MAX/MIN changeover function
- exact setting by means of coding switches
- sensor supply for two-wire input transducers

### Options

- optional inputs
- switching point ON and OFF separately adjustable (see data sheet **vgw-dcn**)



vgw-e



vgw-ec



vgw-d



vgw-dc

### Specification

Style	DIN standard case	ABS f. snap mounting as per EN50022
	dimensions	45x75x105mm (WxHxD)
Type of protection		IP20, terminals guarded
Ambient	operating temp.	-10...+55°C
	shelf temperature	-20...+70°C
	humidity	0...95%
Input	switchable	current 0/4...20mA $R_i=50\Omega$ voltage 0...10V $R_i=50k\Omega$
Setting sensitivity	<b>vgw-e</b>	1x precision pot. with rotary dial $\pm 1\%$
	<b>vgw-d</b>	2x trimmer with slotted dial $\pm 5\%$
	<b>vgw-ec / -dc</b>	1x/2x coding switch $\pm 0,2\%$ , 1% resolution
Output	1 / 2 relay contacts	250V/3A AC max. changeover contact
	time delay	approx. 0,5s
Hysteresis	adjustable	0,5...10% (1%=standard setting)
Switching function	min / max	each output switchable
Sensor supply	terminal 1 / 3	approx. 20V DC / 25mA max.
Accuracy	typically	$\pm 0,2\%$ of full scale, linearity 0,1%
	temperature drift	0,01% /K
Power supply	AC	24, 42, 110, 230V AC, 47...63Hz, 3VA,
	DC	24V DC, 80mA max., -10%/+15%

### Connect. plan 2-wire converter

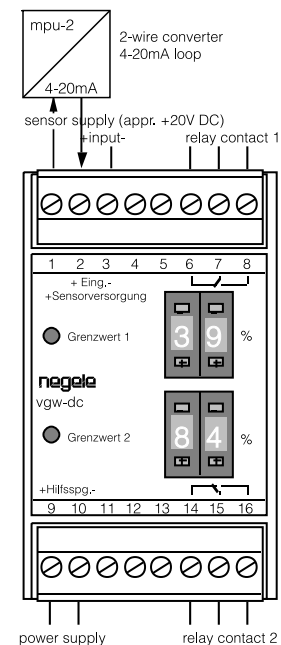

### Connection diagram current / voltage input

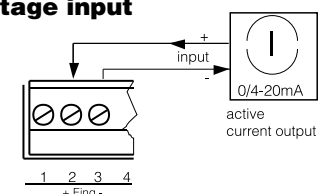

**Order Markings and Types**

model	setting	24V AC	115V AC	230V AC	24V DC
1 alarm value	1x potentiometer	vgw-e 24V AC	vgw-e 115V AC	vgw-e 230V AC	vgw-e 24V DC
2 alarm values	2x trimmers	vgw-d 24V AC	vgw-d 115V AC	vgw-d 230V AC	vgw-d 24V DC
1 alarm value	1x coding switch	vgw-ec 24V AC	vgw-ec 115V AC	vgw-ec 230V AC	vgw-ec 24V DC
2 alarm values	2x coding switches	vgw-dc 24V AC	vgw-dc 115V AC	vgw-dc 230V AC	vgw-dc 24V DC

**Trimmers and setting switches**

name	function	setting
S1	input (I/U)	current(I) / voltage (U)
S2	current input (0/4mA)	0-20mA / 4-20mA
S3	switching function alarm value 2	min / max
S4	switching function alarm value 1	min / max
P1	zero setting (N)	never change
P2	gain setting (V)	never change
P3	hysteresis alarm value 2	0,5... 10%
P4	hysteresis alarm value 1	0,5... 10%

**Device settings**

1. Set alarm relay with "S1" and "S2" to required input.
2. Set switching function for alarm value 1 and 2 as needed ("S3"/"S4").
3. Connect setpoint transmitter or other signal source to input (terminals 2/3).
4. Apply power supply (terminals 9/10).
5. Adjust required alarm values (e.g. 50%) by means of coding switches.
6. Slowly increase or reduce respectively the input signal up to the set alarm value and check the switching function.
7. Set by means of trimmer "P3" or "P4" respectively the hysteresis you need (0,5... 10%) and check by means of changing the input signal.

**view vgw-d/-dc (cover open)**

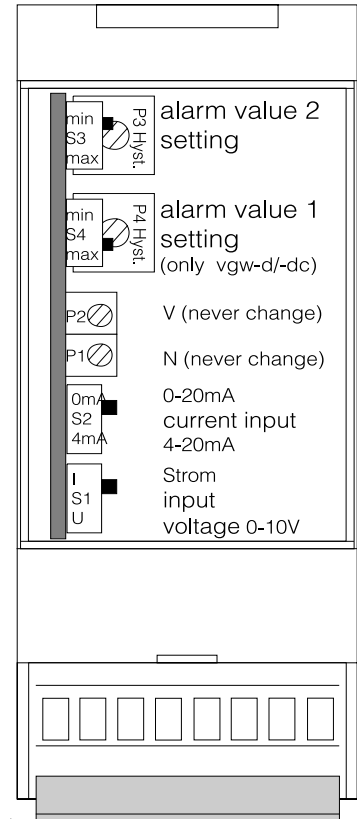

**Status diagrams (input 0-20mA or 0-10V)**

**Function maximum alarm value**

- switch S3 / S4: "max"
- alarm value: 50%
- hysteresis: 10%

**diagram 1**

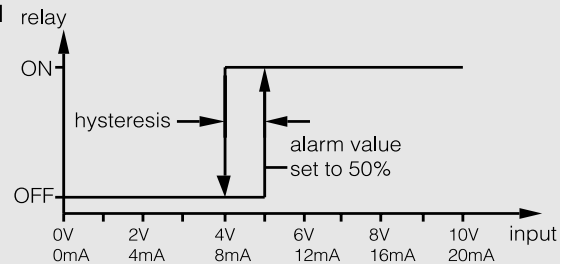

**Function minimum alarm value**

- switch S3 / S4: "min"
- alarm value: 50%
- hysteresis: 10%

**diagram 2**

