

Relative Turbidity Meter ITM-3

Application / Specified Usage

- Media with a turbidity > 2000 NTU / 500 EBC (equal to about 5,5 % of display ITM-3)

Application Examples

- Phase separation of products (for example whey – cream – milk)
- CIP-return line (monitoring of pre-rinse water to product leftovers)
- Yeast harvest in breweries
- Quality control
- Leakage control of filter and gaskets

Hygienic Design / Process Connection

- By using Negele weld-in sleeves / adapters of the **CLEANadapt** system or the build-in system EHG-.../ 1/2" a flow optimized, hygienic and easy sterilizable installation will be achieved.
- Version with 3-A certificate deliverable (TriClamp)
- CIP- / SIP-cleaning up to 140 °C / maximum 30 minutes
- Product contacting materials compliant to FDA
- Sensor made of stainless steel, immersion piece made of PEEK
- Optics made of high resistant sapphire glass
- Additional process connections:
TriClamp, dairy flange (DIN 11851), DRD, Varivent, APV u.a.

Features / Advantages

- Patented, frontflush sensor
- Independent to reflexions at small diameters or electro-polished surfaces
- 100 % compatible to antecessor ITM-2, mechanical and electrical
- No color dependency (wave length 860 nm)
- Smallest pipe diameter: DN 25
- Four measurement ranges, two externally switchable
- High reproducibility: ≤ 1 % of full scale
- Switching output (switchpoint and hysteresis free adjustable)
- Analog output 4...20 mA (standard)

Options / Accessories

- Electrical connection with M12 plug-in connector
- Preassembled cable for M12 plug-in connector
- Remote version (electronics and sensor separated)

Measuring Principle of the Relative Turbidity Meter

An infrared diode irradiates infrared light into the media. Particles in the media reflecting the irradiated light which is detected by the receiver diode (back-scatter principle). The electronics calculates the relative turbidity of the media according to the received signal.

The relative turbidity is based on the Negele calibration standard and is displayed in "%TU".

Authorizations



ITM-3 with EMZ-132



ITM-3/FF sensor with EMZ-132



Measurement Principle

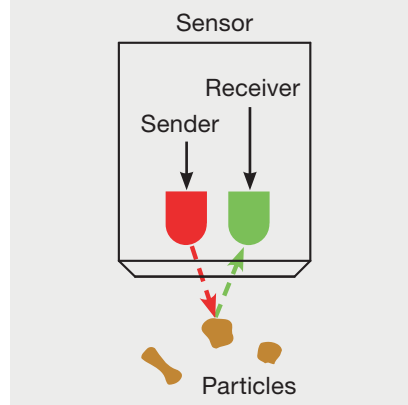

Specification		
Process connection	thread torque	G1/2" sensor, combined with Negele-weld-in sleeves maximum 20 Nm
Materials	connector head thread connection immersion piece optics window in lid sealing optics-immersion piece	stainless steel 1.4305 (303), Ø 89 mm stainless steel 1.4305 (303) stainless steel 1.4435 sapphire glass PMMA EPDM (option: silicone with 3-A approval)
Temperature ranges	ambient process CIP- / SIP-cleaning	-10...+60 °C 0...100 °C up to 140 °C / maximum 30 minutes
Operating pressure		maximum 16 bar
Protection class		IP 69 K (with M12 plug-in connector)
Measurement range	adjustable	0...10 / 20 / 50 / 100 / 200 %TU factory setting: 0...100 %TU
Reproducibility		≤ 1 % of full scale
Accuracy (* %TU = relative turbidity units acc. to Negele calibration standard)		±2 %TU*
Reaction time	damping (T ₉₀) adjustable	0, 1, 3, 6, 13, 25 sec, factory setting: 6 sec
Electrical connection	cable entry cable connection power supply	2 x M16 x 1,5 (PG) 2 x M12 plug-in 1.4305 (303) 18...36 V DC, maximum 150 mA, galvanically isolated
Sensor cable (only ITM-3G)	PUR-cable	4-pin, shielded with M12 plug-in/connector length 5 m (standard), 10 m, 25 m
Inputs	measurement range setting	18...36 V DC, galvanically isolated
Outputs	analog switching output hysteresis adjustable	4...20 mA (scaled to measurement range), supply -0,6 V active maximum 50 mA, short-circuit proof switching threshold free adjustable 0...100 %, factory setting: 5 %
Display	LCD with backlight	2 x 8-digit
Measurement principle	infrared backscatter principle	acc. to EN7027 (wave length 860 nm ± 20 nm)
Weight		ca. 1600 g

Mechanical Connection / Installation



- The sensor has to be installed in that way that the sensor tip is entirely washed around by media and no bubbles can occur. Installation in a rising pipe is recommended.
- If weld-in sleeve is correctly mounted the axis between the 2 connectors points in flow direction.
- For installation in horizontal pipes from top the standard sensor with 15 mm sensor tip is recommended to avoid the influence of bubbles to the measuring signal.
- Attention: The maximum tightening torque for mounting is 20 Nm!

Dimensioned Drawing ITM-3

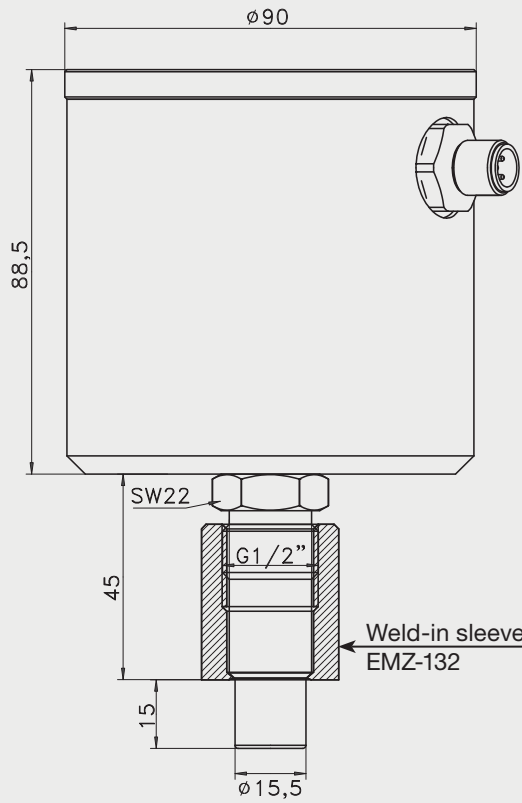

Dimensioned Drawing nozzle ITM-3 / FF

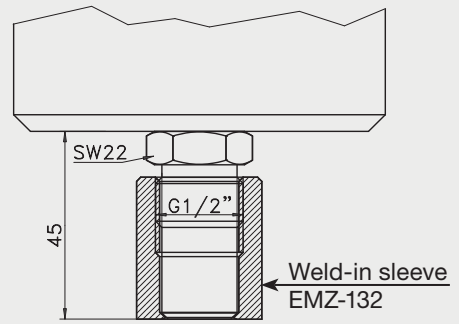

Dimensioned Drawing nozzle ITM-3 / TC2

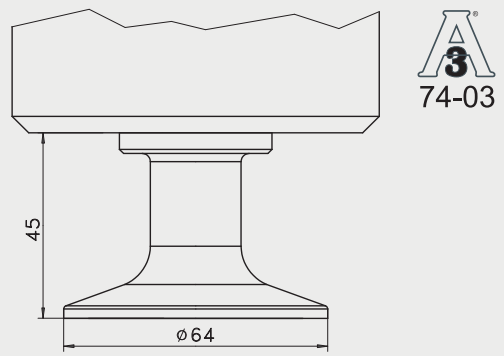

Dimensioned Drawing ITM-3G (Sensor)

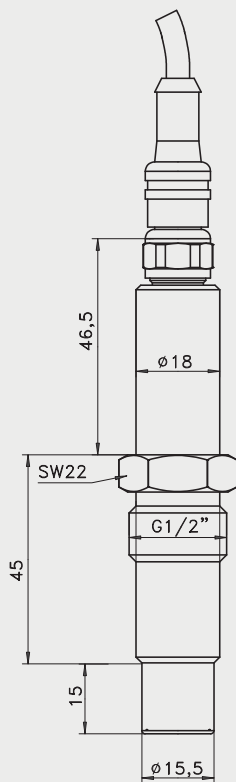

Dimensioned Drawing ITM-3G (Electronics)

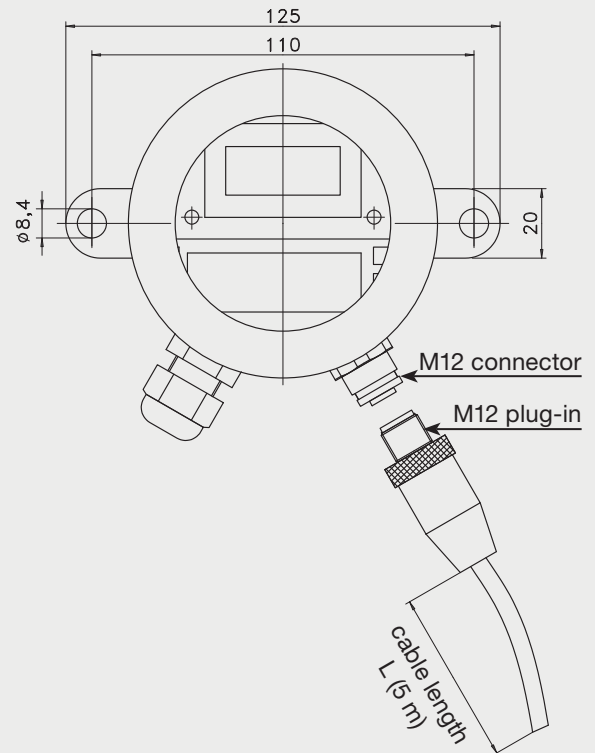

In- and Output Length

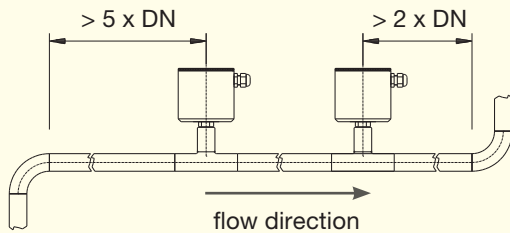

Note



- Select suitable measurement range in applications with high turbidity variances (e.g. milk / milk water mixture) for precise measurement!

Adjustment

- The factory setting of the device is measuring range 1 (0...100 % = 4...20 mA).
- With an external control voltage (24 V DC) range 2 can be selected (E1 = 24 V DC). (See "Electrical Connection")

Switching the Measurement Range

- The digital control input E1 is galvanically isolated from the power supply. Ground: clamp 9 (0 V)

E1*	Measurement Range
0	1 (factory setting: 0...100 %)
1	2 (factory setting: 0...10 %)

* 0 = 0 V DC / 1 = 24 V DC

Calibration



Device is calibrated ex works. A periodical calibration is not necessary. To check the sensor drift perform the following steps:

- Clean the optics and immerse the sensor into a basin with distilled water.
- Ensure that no air bubbles or dirt particles falsify the measurement and agitate the sensor slightly.
- The ITM-3 shows a value between 0,4...0,7 % for distilled water.
- If displayed value is outside the specified range, send the unit in for recalibration.

Note ITM-3G (remote version)



- Evaluation unit and turbidity sensor are calibrated on each other by factory. Therefore could be differences in accuracy when changing sensor and electronics afterwards. To ensure a safe function we recommend to send the device to Negele for a factory calibration.
- Sensor cables has to be changed only with cables of the same length.
- Use only original sensor cables "ITM-3 Sensor cable" by Negele.

Showcase Diagram of different Media

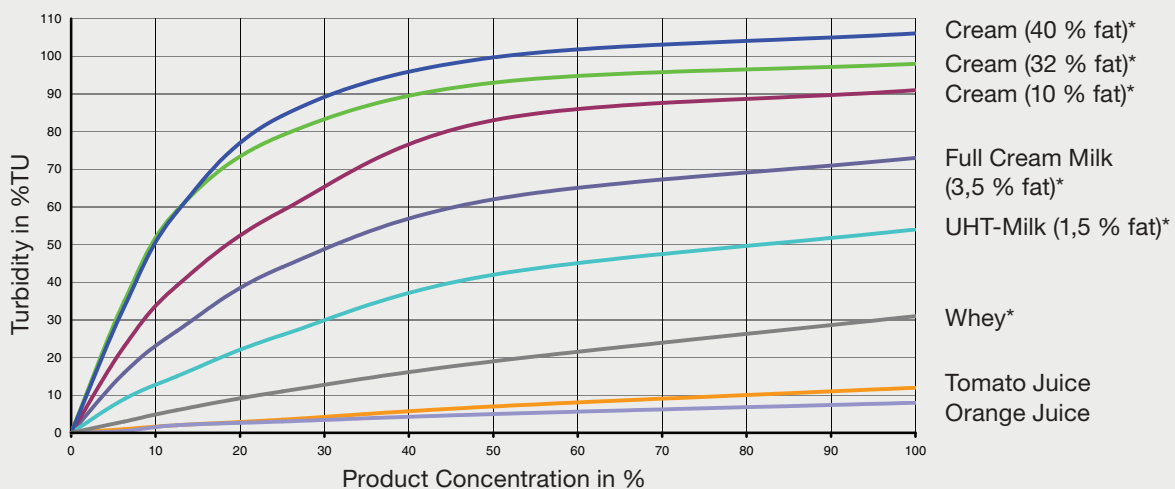

* Average turbidity of customary milk products at different dilutions.





Turbidity Diagram

Depending on particle form and size, the slope of the characteristic curve is decreasing while turbidity is increasing. This is primarily caused by dampening/absorption effects due to multiple reflections inside the media. The turbidity measured in the production process can deviate from the graphs shown above, depending on product, process step and production process.



Compatibility and Antecessor

The measurement characteristic of turbidity meter ITM-3 is identical to the antecessor ITM-2 Rev. B.

Advice to the measurement characteristic of the antecessor ITM-2 Rev. B:

Due to design changes in the optical sensor part the measurement characteristics of the ITM-3 has changed effective from production date as of May 2009.

ITM-2 of this type are labeled with "Revision B" on the type label (see figure) and differ in measurement characteristic from devices delivered between September 2006 until April 2009.

Turbidity meters which were produced in named-above period are showing a lower turbidity value at high product concentrations (depending on the media) than ITM-3 or ITM-2 labeled with "Rev. B" (see diagram below).

To replace units which were produced between September 2006 and April 2009 with current devices a recalibration of threshold level and output is required.

Elder devices with production date before September 2006 have the same measurement characteristics like ITM-3 and ITM-2 with "Rev. B" as of May 2009 and can be replaced one by one.

+49 8333 9204 0	negele
D-87743 Egg a.d. Günz	
Trübungsmessgerät ITM-2	
Anzeige: 0...100 %	
Ausgang: 4...20 mA Schaltausg: 50 mA	
Supply: 18...36 V DC	
(Rev. B)	
P.-Nr: 110000783618-005 16/2009	

Changed Measurement Characteristic at ITM-3 and ITM-2 Rev. B (as of May 2009) | Example: Cream (40 % fat)

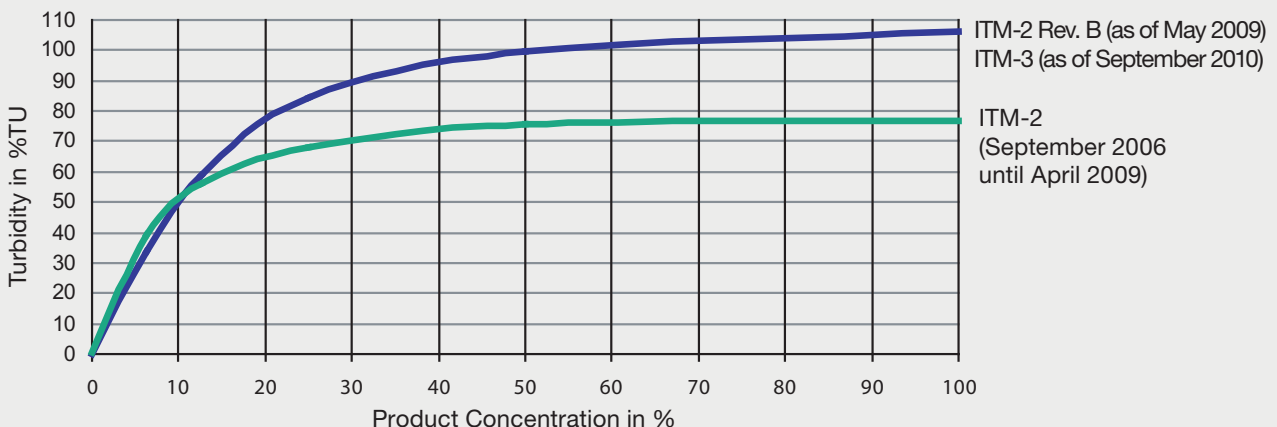

Conventional Usage

- Not suitable for applications in explosive areas.
- Not suitable for applications in security-relevant equipments (SIL).

Advice to EMV

- Applicable directives:
- Electromagnetic Compatibility Equipment Directive 2004/108/EC
 - The CE label confirms compliance of this product with the applicable EC directives.
 - You have to guarantee the EMC directives for the entire equipment.

Electrical Connection ITM-3 | ITM-3G

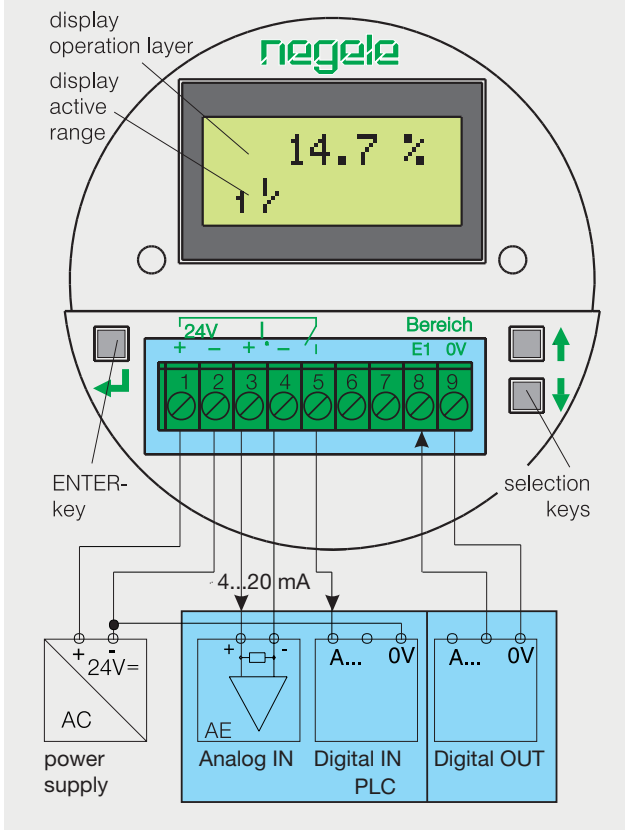

Specialities of ITM-3G with M12 Plug-In



· Attention: The external range setting / switching output functions of the remote version (ITM-3G/.../M12) are not connected by default!
 In case the analog output is unused, the switching output can be connected to the M12 plug by rewiring the internal screw-connector as follows:
 clamp 4 (blue cable) disconnect and isolate
 clamp 3 (white cable) change to clamp 5
 · The switching output is now connected to pin 2 of the M12 plug-in.
 (reference: ground of power supply)

M12 Plug-In Configuration ITM-3/.../M12

M12 plug-in left (4-pin) outputs 4...20 mA

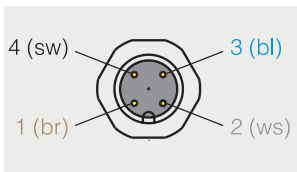

1. + output turbidity
2. switching output +
3. not connected
4. - output turbidity

M12 plug-in right (5-pin) supply- / control voltage

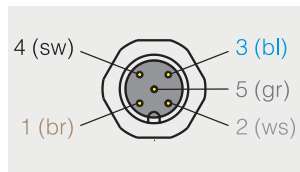

1. + 24 V power supply
2. not connected
3. 0 V
4. - power supply
5. E1 range setting

M12 Plug-In Configuration ITM-3G/.../M12

M12 plug-in left (4-pin) power supply and output

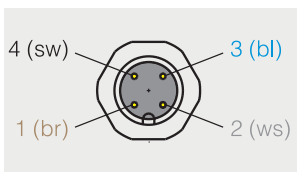

1. + 24 V power supply
2. + output turbidity
3. - output turbidity
4. - power supply



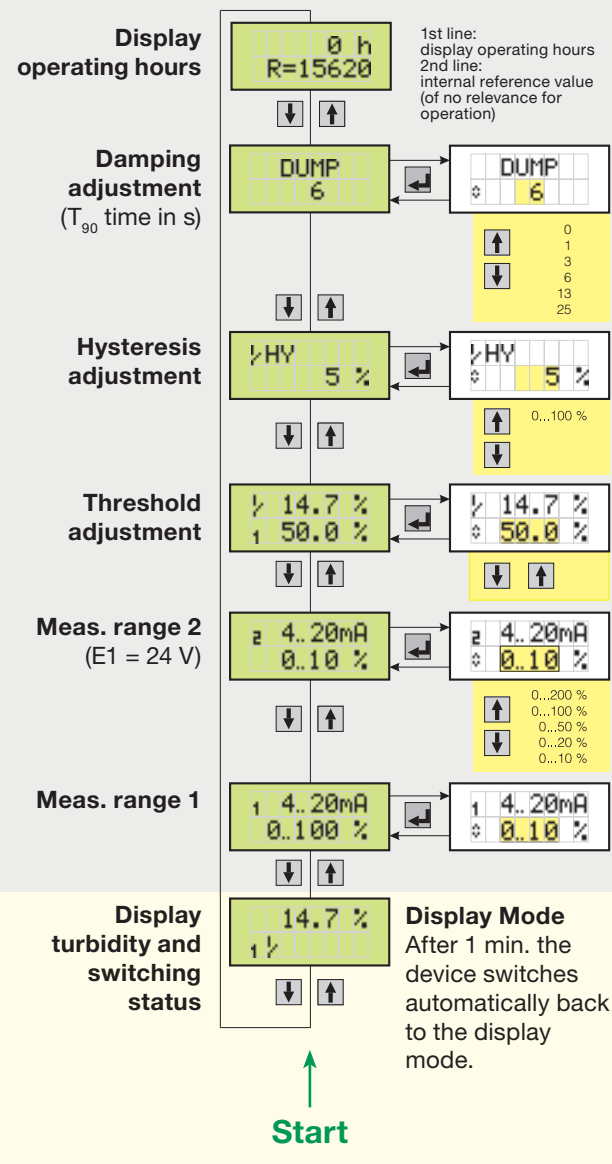

Installation ITM-3

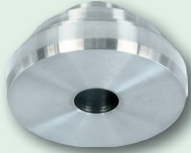
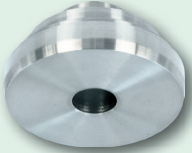

Overview of further possible process connections (adapter must be ordered separately!)
The complete overview of all available adapters you will find at product information **CLEANadapt** in chapter 1.

ITM-3					
Process connection	Build-in system EHG (DIN 11850 series 2)	Negele weld-in sleeve	Negele weld-in sleeve	Collar sleeve	TriClamp
DN25	EHG-DIN2-25/ 1/2"	EMZ-132 suitable for installation in vessels	EMS-132 suitable for installation in pulled-out pipes	EMK-1 suitable for thick-walled vessels	AMC-132/DN25
DN40	EHG-DIN2-40/ 1/2"				AMC-132/DN25
DN50	EHG-DIN2-50/ 1/2"				AMC-132/DN50
DN65	EHG-DIN2-65/ 1/2"				-
DN80	EHG-DIN2-80/ 1/2"				-
DN100	EHG-DIN2-100/ 1/2"				-

Overview of further possible process connections (adapter must be ordered separately!)

ITM-3					
Process connection	Dairy flange (DIN 11851)	DRD (press ring optional)	Varivent-Inline	APV-Inline	Dummy flange
DN25	AMK-132/DN25	-	AMV-132/25	-	BST-132 for closing an existing measurement point
DN40	AMK-132/DN40	AMK-132/50 (only one size)	AMV-132/40	AMA-132	
DN50	AMK-132/DN50		AMV-132/40	AMA-132	
DN65	AMK-132/DN65		AMV-132/40	AMA-132	
DN80	-		AMV-132/40	AMA-132	
DN100	-		AMV-132/40	AMA-132	

Transport / Storage



- No outdoor storage
- Dry and dust free
- Not exposed to corrosive media
- Protected against solar radiation
- Avoiding mechanical shock and vibration
- Storage temperature -20...+60 °C
- Relative humidity max. 80 %

Reshipment



- Sensors shall be clean and must not be contaminated with dangerous media! Please note the advice for cleaning on page 8!
- Use suitable transport packaging only to avoid damage of the equipment!

negele

Cleaning / Maintenance



- Don't use sharp items or aggressive detergents for cleaning the optics.
- In case of using pressure washers, don't point nozzle directly to electrical connections!

Disposal



- This instrument is not subject to the WEEE directive 2002/96/EG and the respective national laws.
- Pass the instrument directly on to a specialised recycling company and do not use the municipal collecting points.

Order Code

ITM-

Sensor Version

3 (compact unit)

3G (remote version, including electronics, sensor and 5 m sensor cable)

Process Connection

X (CLEANadapt G1/2", 15 mm sensor tip)

FF (CLEANadapt G 1/2", frontflush)

TC 1,5" (TriClamp, frontflush)

TC 2" (TriClamp, frontflush)

Electrical Connection

X (2 x cable gland M16 x 1,5)

M12 (2 x M12 plug-in;

Attention: note the advice on page 6 at version ITM-3G!)

Sensor Cable (only for remote version ITM-3G)

X (length 5 m)

10M (length 10 m)

25M (length 25 m)

ITM - 3 / X / M12

Accessories

ITM-3G sensor cable with M12 plug-in/connector made of PUR, 4-pin, shielded

M12-PUR / 4-5 m	length 5 m
M12-PUR / 4-10 m	length 10 m
M12-PUR / 4-25 m	length 25 m

Note: The sensor cables are included in delivery of ITM-3G.

PVC-cable with M12-connection, 1.4305 (303), IP 69 K, unshielded

M12-PVC / 4-5 m	4-pin, length 5 m
M12-PVC / 4-10 m	4-pin, length 10 m
M12-PVC / 4-25 m	4-pin, length 25 m
M12-PVC / 5-5 m	5-pin, length 5
M12-PVC / 5-10 m	5-pin, length 10 m
M12-PVC / 5-25 m	5-pin, length 25 m

PVC-cable with M12-connection, brass nickel-plated, IP 67, shielded

M12-PVC / 4G-5 m	4-pin, length 5 m
M12-PVC / 4G-10 m	4-pin, length 10 m
M12-PVC / 4G-25 m	4-pin, length 25 m
M12-PVC / 5G-5 m	5-pin, length 5 m
M12-PVC / 5G-10 m	5-pin, length 10 m
M12-PVC / 5G-25 m	5-pin, length 25 m

M12-EVK M12 plug-in screw cap, 1.4305 (303), with o-ring, as a protection against humidity and dirt

CERT/2.2 factory certificate 2.2 acc. to EN10204 (only product contacting surface)
CAL/ITM-3 factory calibration for ITM-3